

## EXTENSION STRATEGIES TO STIMULATE LIVESTOCK PRODUCTION IN NIGERIA

By

DR. M. IBI AJAKAIYE

*Acting Director*

*Agricultural Extension and Research Liaison Service,  
Ahmadu Bello University, Zaria, NIGERIA*

### INTRODUCTION

- (1) The development of the full potential of Nigeria's livestock industry will be very difficult to achieve if it is left to be dominated by the age-long traditional system of animal husbandry as practised by the traditional livestock raisers.

In a developing economy like Nigeria where the demand for meat and other products far exceeds the supply, and where previous efforts at encouraging the traditional livestock raisers to step up their production through adoption of improved method of animal husbandry have yielded little results, the need for very strong and effective livestock extension strategies to stimulate livestock production cannot be over-emphasized.

In Nigeria, approximately 80—90% of the cattle population, 61% of the sheep and 68% of the goats are owned by the nomadic Fulani cattle rearers. They are evidently the major suppliers of meat, milk and other animal products for the entire country. It is apparent that the situation will continue as it is for a long time as there are presently no counter-indications. But the main concern is that it is clear that the traditional

system can no longer cope with the ever-increasing demand for meat and other animal products.

But with the acceptance that the country must as of necessity rely on this source for its meat supply for sometime to come and also appreciating the inability of the system to cope with the demand one is forced into a whole sequence of realisations.

1. Owing to the uncertainties associated with attempts to sedentarize a group of people who have grown accustomed to a nomadic way of life, we have a situation which is rife with difficulties.
2. As an alternative to the dire consequence of enforcing settlement, it would seem necessary to diversify efforts in the direction of evolving a new breed of livestock raisers.

The suggestion therefore is that while efforts are being intensified at encouraging the traditional livestock raisers, to improve their production through adoption of modern animal husbandry practice it is hoped that the new breed of livestock raisers who will comprise of other livestock farmers will be more amenable to innovations.

## EXTENSION STRATEGIES IN LIVESTOCK PRODUCTION

### EXTENSION EFFORTS UP TO DATE

The concept of extension is a recent innovation in the livestock sector and it is only in the last couple of years, that the subject of extension has been introduced in the curricula of both the veterinary schools and Animal Husbandry courses. Emphasis has mostly been placed on disease control in the livestock segment probably because of the predominance of disease problems in the country right from the start (Yazidu 1978). Extension efforts have been mainly in the areas of training of extension personnel, building up the institutions necessary for carrying out extension work, supply of improved stock, nutrition and feeds, disease control and eradication.

Training of extension personnel began in 1930 at Kano but was later transferred to Vom. The livestock services training centre (now College of Agriculture and Animal Husbandry) was established in the late 60's. The Institute of Agricultural Research and Training, Moor Plantation Ibadan has also long been involved in the training of extension workers for the livestock industry. Since the creation of the more states in 1976, a number of states have embarked on the establishment of colleges of Agriculture in order to increase the out-put of agricultural extension workers. These institutions are involved in the training of the junior and supervisory cadre of staff. The Universities of Ibadan, Ife, Nsukka and Ahmadu Bello University have been producing animal science and veterinary medicine graduates. Of the newer universities it is anticipated that the University of Sokoto, Maiduguri etc. will soon begin to release their first graduates in Agriculture.

Extension work in the livestock sector has been the primary responsibility of the Ministries of Agriculture and Natural Resources. In most states there is one divi-

sion, the veterinary division that carries out this responsibility. In some states however, there is also an Animal Husbandry division. The relationship between the various cadres of staff in these divisions is as given in Table 1: At the Federal level, the Federal Livestock Department was established in 1969 and charged with the responsibility for "national policy, co-ordination, advice and implementation of national livestock projects" (FLD 1976). The Director of the Federal Livestock Department is the chairman of the National Livestock Development Committee which is responsible to the national council for Agriculture and Natural Resources.

Charged with the responsibility for research are the National Animal Production Research Institute, The National Veterinary Research Institute, The Nigerian Institute for Trypanosomiasis Research and the Leather Research Institute of Nigeria. These together with the Colleges of Agriculture and the Universities are actively involved in research on all aspects of animal production, vaccine production disease control and animal products utilization.

The Nigerian Livestock and Meat Authority was established in 1962 to undertake commercial production and marketing services for Northern Nigeria. In 1966 it took on a Federal character. The organisation has however been dissolved and its functions have been shared out between the Federal Livestock Department and the newly created Nigerian Livestock Production Company.

The Agriculture Extension and Research Liaison Services of Ahmadu Bello University was initially established as an arm of the Samaru Research Station in a bid to hasten the dissemination of research results to the farmers. In 1976 it became an autonomous institution. This

organisation has been unique in its extension efforts and has been widely acclaimed as a model of an extension effort in Nigeria.

### **BOTTLENECKS TO SUCCESSFUL EXTENSION WORK IN THE LIVESTOCK SECTOR OF OUR AGRICULTURAL ECONOMY**

In spite of the efforts listed above extension work in the livestock sector has achieved little in comparison to those in the crops sector of our agricultural economy. Shiawoya (1976) Nuru (1979) and Ajakaiye (1979) have pointed out some factors responsible for this ineffectiveness amongst which are:-

1. Manpower shortage, both in terms of quantity and quality.
2. Lack of reliable statistics on livestock populations and their utilization to enable the planners to formulate suitable policies.
3. High Prevalence of livestock diseases e.g. trypanosomiasis, C.I.B.P.P. brucellosis gumboro, newcastle disease etc.
4. Inadequate co-ordination, poor planning and execution of livestock development projects at Federal and state levels.
5. Nomadism and illiteracy of the Fulani cattle rearers who control about 90% of the cattle in Nigeria.
6. Financial stringencies which have resulted in inadequate financial allocation to the livestock sector. In one state for example, the veterinary division was allocated N4,000 for drugs and equipment for the 1979/80 financial year.
7. Insufficient incentives and transportation facilities for extension personnel and livestock farmers.
8. Poor quality and high cost of commercial livestock feeds.

9. Shortage of essential inputs necessary for adoption of improved production techniques.
10. Inadequate credit facilities for livestock farmers which makes it difficult for many trained agriculturists to go into livestock production themselves and thus show by example that unproved production techniques does pay.

Most of these problems are inter-related. It will therefore be proper to discuss these under broad headings and also suggest ways by which they can be remedied.

### **SUGGESTED EXTENSION STRATEGIES TO STIMULATE LIVESTOCK PRODUCTION**

Extension can be defined as an agency of change. It is regarded as the processes involved in the transfer of modern technology from technologically developed countries and research institutions to the rural communities. Its mode of operation is by persuasion in teaching of appropriate technologies so that clients can adopt them for their benefits.

Yazidu (1978) defined extension in the livestock sector as informal education organised by democratic means to assist livestock owners to improve their knowledge and skills through their own efforts thereby improving their living standards and increasing the production of livestock products.

Extension work is in its infancy in the livestock sector of our agricultural economy. Very little impact has been made on the traditional livestock farmers. One cannot but compare this with the role extension has played in educating farmers to improve on their crop farming techniques which has given rise to wide acceptance of modern farming technology such as the use of improved varieties of crops, fertilisers, pest control, storage techni-

## EXTENSION STRATEGIES IN LIVESTOCK PRODUCTION

ques etc. There is no single improved livestock production technique that has been adopted to the same magnitude with what has been achieved in the crops sector. Yet we know that the technology is available in the country. Balogun (1976) gave a vivid comparison of the production and health status of the animals at the Shika research station and the animal owned by traditional livestock farmers in the same vicinity. This depicted a very wide gap in the production and health status of the two groups of animals. The major problem here is the lack of an effective system coupled with the unavailability of essential in-puts. The following strategies are suggested as a means of bringing this wide gap and are considered possible to achieve under Nigerian conditions.

### 1. *The Institutional Framework:*

In order to establish an effective extension system, there must be an effective and dynamic framework that will deliver the goods of modern technology to all categories of livestock farmers. Some of the problems such as poor planning and execution of livestock development projects and the chronic manpower shortage should have been minimised if the present institutional framework was not in existence.

The National Livestock Development Committee as the highest legislative organ should be properly composed to make it more efficient and dynamic in its great task of evolving policies, planning and execution of livestock development programmes for the whole country. Its present membership has already been criticised at two previous conferences (Ademosun 1976, 1978). Over 90% of its membership is restricted to Veterinarians. It has therefore been suggested that in order to

make it more efficient, its membership should be expanded or re-composed to include all the major professions that are concerned with livestock production in Nigeria. There should be a balance in membership between veterinarians, animal nutritionists, breeders, pasture and management experts, extension specialists, other animal scientists, rural sociologists and agricultural economists. This suggestion appears to have fallen on deaf ears so far but it is time for it to be critically examined and implemented so that the functions of the NLDC will be more appreciated and effective than at present.

It is gratifying to observe that the Federal Livestock Department has undergone massive re-organisation within the past three years. It is believed that this will make it more equipped and effective in carrying out its activities. An open door policy should be maintained and incentives provided that will enable it to attract capable staff from all professions within the livestock sector.

One of the resolutions passed at the 1978 conference of the Nigerian Society for Animal Production was for the creation of Livestock Services Division to be headed by a Chief Livestock Officer in each state Ministry of Agriculture and Natural Resources. This call is most timely since it is at this level that extension work is carried out at the 'grassroots,' it is important that a system which brings together all the livestock experts harmoniously be established. The present system has already been described (Table 1 and 2). In most states of the Federation, a *Veterinary division is responsible for extension work in the livestock sector. This has a number of set backs:-*

- (i) It results in a greater emphasis being placed on disease control aspects of

TABLE I

PERSONNEL RANKS IN THE LIVESTOCK EXTENSION SERVICES SECTION  
OF THE MINISTRIES OF AGRICULTURE

## TYPE A ARRANGEMENT

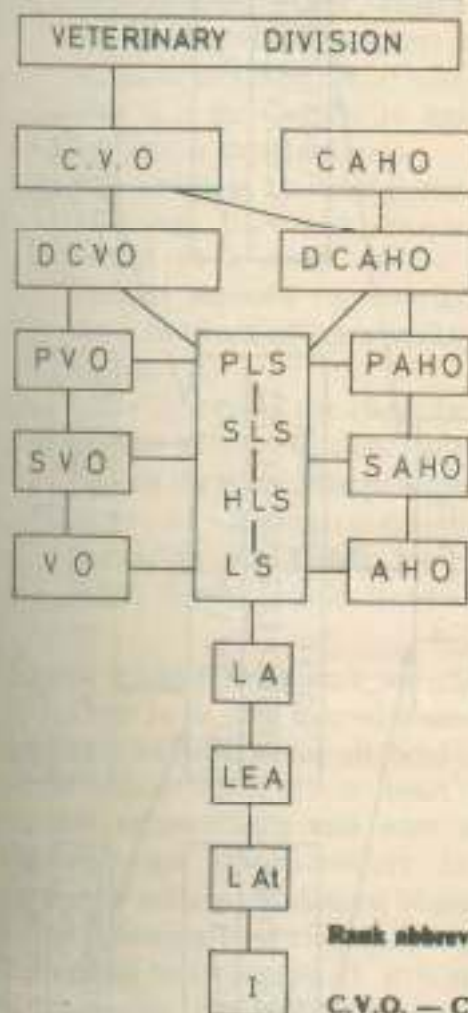

## TYPE B ARRANGEMENT

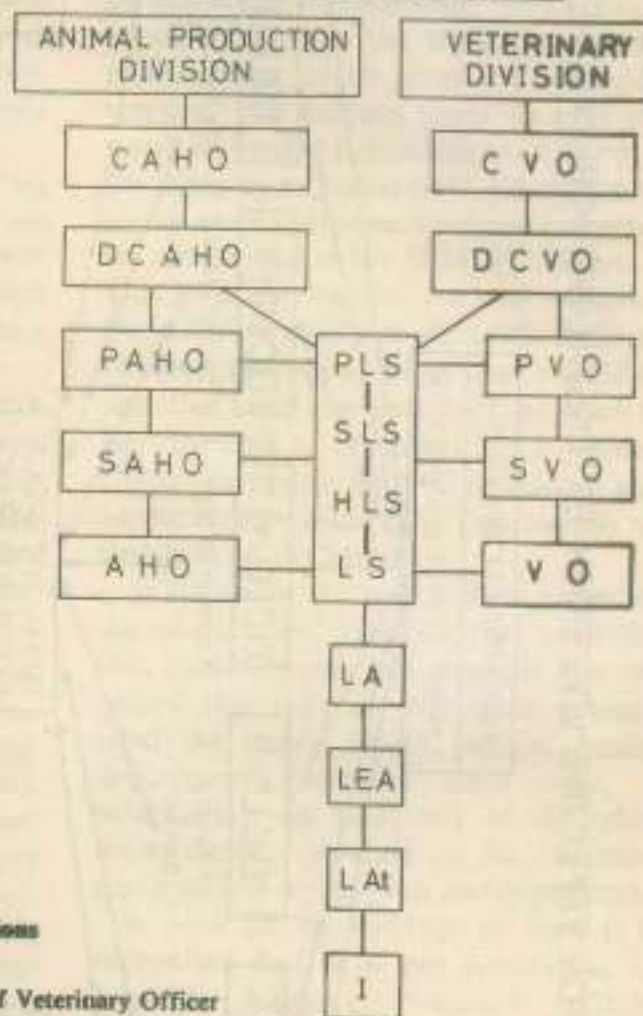

## Rank abbreviations

- C.V.O. — Chief Veterinary Officer  
 D.C.V.O. — Deputy Chief Veterinary Officer  
 P.V.O. — Principal Veterinary Officer  
 S.V.O. — Senior Veterinary Officer  
 V.O. — Veterinary Officer  
 C.A.H.O. — Chief Animal Husbandry Officer  
 D.C.A.H.O. — Deputy Chief Animal Husbandry Officer  
 P.A.H.O. — Principal Animal Husbandry Officer  
 S.A.H.O. — Senior Animal Husbandry Officer  
 A.H.O. — Animal Husbandry Officer  
 P.L.S. — Principal Livestock Superintendent  
 L.A. — Livestock Assistant  
 L.E.A. — Livestock Extension Assistant  
 L.A. — Livestock Attendant  
 I. — Innoculator

SUGGESTED MODEL FOR EFFECTIVE LIVESTOCK EXTENSION NETWORK AT THE STATE LEVEL

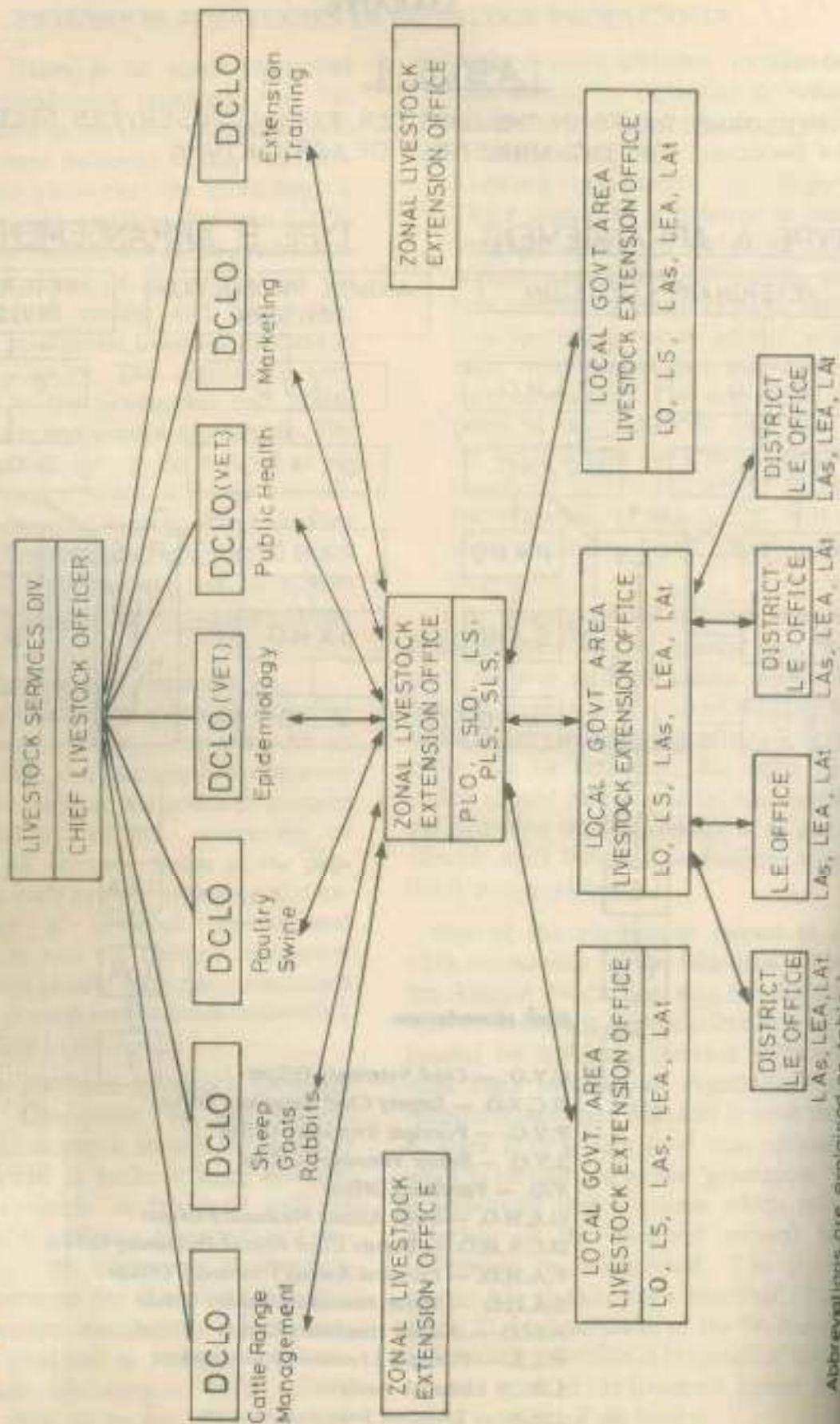

Abbreviations are explained on table 1

the livestock industry, whereas in other parts of the world emphasis is on Production through good management. We all know that a lot of disease problems can be prevented by good management practices.

- (ii) The Veterinary division is and should rightly be headed by a veterinarian. This means that animal husbandry experts cannot aspire to this position of leadership. This is a disincentive to hardwork and career expectations.
- (iii) It is common knowledge that a lot of energy time and resources are wasted as a result of the power struggle between veterinarians and other livestock officers working in a set up.
- (iv) In recognition of the above factors a number of animal science graduates have in the past deflected into other arms of agriculture, thereby decreasing the higher level manpower shortage in the livestock sector.

From AERLS experience we are convinced that to be able to evolve an effective extension programme all those engaged in animal production must work together harmoniously and must accept that they are complimentary to one another to achieve the desired objectives.

The following institutional framework is therefore being suggested. It is similar to an earlier one suggested by Nuru (1979).

This model (Table 2) recommends that the division be named a livestock services Division to be headed by a Chief Livestock Officer. Every graduate on entering the service be offered the post of livestock Officer II animal science graduates & livestock I for Veterinarians. The common title of livestock officer is similar to what obtains in research institutes where graduate technical staff are

all referred to as research officers no matter their profession. Similarly we have Agricultural Officer as a common title for most graduate staff in the Ministries of agriculture even though some are Engineers and some are Economists.

It is suggested that the division be divided into sections or departments depending on the needs of each state. The division should recognise the different subject matter areas within livestock extension services. The modern trend all over the world is towards specialisation in one or a few areas by technical staff. Division into sections will enable each entrant to pursue his career within his field of interest. This gives job satisfaction and improves the technical ability of the staff. In terms of career prospects, the sections should be such that every graduate staff can reach at least the rank of a deputy Chief Livestock Officer no matter his field of interest and no matter how many others are already on that rank in the Ministry.

What about the professional status of the veterinarian? This proposal takes this into consideration. For example it is expected that only a veterinarian should head the public health, animal health departments. At the same time, a veterinarian can head any of the other departments depending on his interests, postgraduate orientation and experience.

In view of the shortage of staff it is recognised that, it is not possible as of now to have a livestock officer (Veterinary) in each Local Government Area which should be the ultimate goal. Until this is possible, the creation of Zonal Offices to cater for two — three Local Government Areas is recommended. This is already the practice in most of the Northern States. Each Zone should have at least a Veterinarian Livestock Officer and a fully equipped diagnostic laboratory. Other livestock officers may be sent to the Zonal Offices as they become available. All production centres

should be headed by a production oriented livestock officer. Officers at the zonal offices should be able to rise to the rank of Principal Livestock Officer and still be gainfully employed at that level. This model proposes that officers on or below the rank of principal be actively involved at production centres or Zonal extension offices and may only be kept at the headquarters where there are no other more senior personnel.

The staffing position at Local Government and District Offices proposed in this model aims at making available at least a Livestock Assistant to each District of 2,000 — 5,000 farming families.

The other system that is already obtainable in some states is the establishment of a veterinary division and an animal husbandry division (Table 2). This seems to be possible only in states that can afford it. There also has to be a clear demarcation of responsibilities as well as good co-operation between staff working in the two divisions. Very often the separation is only present at the headquarters since area staff still have to work under one Area Officer in order to give the package approach in extension work. Moreover, the junior and intermediate cadre of staff are trained to work in both divisions. However, it is a better system than lumping everything into a veterinary division.

#### *Integrated Rural Development:*

Livestock farming is essentially the occupation of rural communities. The problem of nomadism and illiteracy has already been identified as one of the bottlenecks to effective extension work. It is therefore of paramount importance that programmes for massive education such as the U.P.E. and adult education be pursued vigorously. In addition the provision of infrastructures such as roads, electricity and water supply will greatly increase the farmers access to inputs and increase

his productive and earning capacity.

The nomadic Fulani cattle rearers in particular must be educated so that they can see livestock raising as an economic venture, a means to improving their living standards rather than just a cultural heritage. Adult education and livestock extension workers should pursue a massive education programme that will enable the nomad see the superiority of modern animal husbandry practice to his own system. The various livestock demonstration centres must be able to show good example; they must be maintained in such a way that livestock extension workers can use them to convince farmers about the importance of modern farming practices. Provision of adequate grazing reserves and settlement facilities is one way to discourage nomadism and make them more accessible to livestock extension workers. The problem of nomadism is very complex and requires the co-operation of many agencies such as; the local government authorities, state governments, federal government agencies, extension organisations and Research Institutions. Yazidu (1978) described an extension effort extended to Fulani herdsmen passing through the Samaru area at certain times of the year. The method was successful except for the inability of the Ministry to provide watering points and grazing reserves as well as land to enable them settle permanently. From this and other small scale trials it is right to expect that the Fulani herdsmen will settle down if the infrastructures are available.

The integrated approach is the principle of operation of the world bank sponsored agricultural development projects. So far some of these projects have proved to be very successful. It is recommended that these projects be expanded to tackle the problems of livestock rearers.

### 3. Staff Training and Provision of Adequate Incentives:

The extension worker is the vehicle through which extension work is conducted. His successes and failures directly reflect on the effectiveness of the extension system. It is therefore very important that he be properly trained and equipped for his duties.

The present training facilities for training appear to be inadequate and often ill equipped. Olumeyan (1978) showed that less than 50% of the number of candidates who were recommended for training at the College of Animal Science, Kaduna in 1977 and 1978 were admitted for training. This is most unfortunate in view of the very low ratio of extension workers to livestock farmers in Nigeria. The result is that many states have often been forced to recruit primary and secondary school leavers and send them out to the field without any formal training. Adeoye (1979) stated that such unqualified staff often did more harm than good to their clients. This is not surprising since he is not adequately trained and equipped to deal with the problems usually brought to him by livestock producers who look up to him as an expert.

The present proliferation of schools of Agriculture may be a step in the right direction. In order to overcome the problems of inadequate staffing and training facilities, such schools should be located near livestock production centres. Senior staff at the headquarter or division offices should assist as part-time staff and the facilities at the production centres should be available for student practicals.

Offering training opportunities to the extension worker is in itself an incentive. In many cases these workers cannot be promoted unless they acquire additional certificates. Many of them are often frustrated because they cannot go for further training. Since the opportunities are

not there the result is poor attitude to work and consequent failure of the extension system.

The provision of adequate incentives is necessary in order to attract the quantity and quality of staff needed for the livestock industry. Very often the school leaver is faced with a choice between working in the city with all its amenities such as pipe borne water, electricity, shops plus all the other goodies of life or taking up a job with the Ministry of Agriculture which means going into the rural areas with none of these things plus other associated problems. In most cases he will take the latter only if there is no alternative employment. Ease of mobility is also a very crucial element for effective extension work. You cannot expect the extension worker to maintain contact with his 2,000 — 5,000 farming families when he doesn't even have a bicycle! The situation has been greatly aggravated by the recent ban on motor vehicle loans and allowances. This situation calls for immediate action by the authorities. The ministry should provide a suitable transport pool for use of extension staff.

### 4. Supply of Essential Inputs:

It is very clear from state annual reports and others, (LD 1975) Yazidu 1978) that the value of essential inputs such as supplementary feeds, and disease control programmes have been recognised even by the Fulani cattle rearer. The publicity team of the J.P. 28 campaign toured Kano and former North Western States extensively and reported that in all places visited the cattle rearers turned up in large numbers and often complained about lack of supplementary feeds, watering points and grazing reserves. AERLS touring notes (1976, '79) confirm the much talked about feed scarcity shortage of day old chicks, inadequate supply of vaccines even for Government farms. Unavailability of distilled water to reconstitute vaccines such as the commercial bank which have

cines was reported in one state capital.

The extension worker is therefore often in a dilemma as to what to do. He may convince a farmer to raise improved breeds but the inputs such as feeds and vaccines for disease control are just not available. It is therefore of paramount importance that all avenues through which inputs can be made available to the livestock farmer should be exploited. Government involvement in direct production has often resulted in poor production and a consequent waste of public funds. A good example is the poultry production units of the defunct Nigerian Livestock and Meat Authority. The fantastic buildings put up for these poultry units are of no value as demonstration centres for other poultry farmers and do not appear to have been designed for a tropical environment.

We hope that the Nigerian Livestock production Company will not be a carbon copy of its predecessor. Government should preferably limit itself to the acquisition and distribution of such inputs as feeds and vaccines while commercial production should be concentrated in the hands of private producers who should be closely supervised to ensure the quality of their products.

This raises another issue, and that is the availability of credit facilities for prospective livestock farmers. There are many agricultural graduates who have the technical know how but do not have the capital with which to start. Similarly, many farmers who want to expand their livestock farms cannot do so due to shortage of funds. It is gratifying that government has in recognition of these problem established a Nigerian Agricultural and Co-operative Bank to grant loans to co-operative societies and individual farmers. There are lots of problems associated with the functioning of this bank as well as other lending institutions such as the commercial bank which have

also been mandated to issue loans for agricultural purposes. The Government should set up a committee to look into these problems and come up with some recommendations that will make more loans available to farmers. This is one way to increase the availability of essential inputs to the livestock farmer.

The OFN programme has played a very prominent role in the supply of some inputs. Olaifa (1979) reported that under the O.F.N. Programme, 50 000 metric tonnes of maize and 11,000 metric tons of poultry feed concentrates were imported since the inception of the programme in 1976.

It is to be recommended that a programme similar to the OFN should be launched in the livestock sector in order to increase the availability of these inputs. A programme such as National Accelerated Livestock Production Programme at this time will be most timely. Research institutions should be adequately funded and encouraged to develop inputs from local resources. This will reduce our dependence on imported inputs which is one reason for their scarcity.

### *5. Productive Utilisation of the Mass Media and Extension Methods:*

The use of the mass media is very important in creating awareness among farmers about new ideas. The extension worker must be adequately trained in their usage. Of all media, the radio (Yazidu and Prawl 1975) has been established as a most powerful means of transmitting information to the rural populace in Nigeria. This is because the advent of cheap transistorised radios have transformed the medium to be the number one medium for massive public education. Fulanis in the bush can be seen among their animals with their small transistor radios strung to their backs or hanging from their shoulders. Very much to our distress of course is the fact that most

of the programmes are irrelevant to his ambitions. For example, he is entertained to rock and roll, indian music, sonny Ade and Fella more often than he hears about agricultural innovations. This poses a serious challenge to our livestock extension agencies and adult education authorities who can actually use this medium for functional education programmes geared to the interest of the Fulani and other traditional livestock farmers.

The television, and print media are within the reach of the literate farmers and urban dwellers and are an invaluable aid to the extension worker. Publications in simple non-technical language produced in local languages have proved to be very useful in extension work. The AERLS of Ahmadu Bello University has successfully produced several and different kinds of publications in this direction. It is recommended that research institutes and Universities co-operate with Extension Organisations to produce many more to cope with the ever increasing demand.

Extension methods such as farm and home visits demonstrations, agricultural shows and use of audio-visual aids enable the extension worker to make personal contact with farmers. Through these visits he can establish good human relationships — a necessary ingredient for effective extension work.

#### 6. *The Role of Veterinarians:*

At the very early stages of livestock development efforts, the emphasis was on the training of veterinarians to cope with high prevalence of livestock diseases.

Little attention was paid to the production aspect. F.A.O. report of 1966 showed that there were 20 veterinarians and no graduate animal scientists in the Northern States. Consequently the veterinarians have been responsible for formulation of policies and execution of livestock

development programmes hence the emphasis on disease prevention at the expense of much needed efforts to increase production.

With the emergence of animal scientists in the livestock industry, one would have loved to see the development of a harmonious working relationship between veterinarians, animal scientists and others involved in animal industry for us to be able to be self sufficient in our animal production system.

The Veterinarians, the animal scientists, the livestock economists, marketing experts should know their roles and functions in the livestock industry. Their roles and functions are interdependent and complimentary to one another.

For example, how can we develop an effective disease control programme when the animals don't have enough to eat.

Therefore one would suggest that the various aspects of our livestock industry should be headed by respective relevant personnel. i.e. the production aspect by animal scientists, disease control diagnosis and treatment of diseases and production of vaccines by veterinarians etc.

AERLS as an extension organisation cannot function properly without the much needed co-operation between the various people involved in animal production.

### CONCLUSION

The problems that militate against the establishment of an effective extension network in the livestock sector of our agricultural economy are numerous and complex. Nevertheless with a better approach to planning and execution, training and provision of adequate incentives for extension workers within an effective institutional framework will go a long way towards solving this problem. The problem of nomadism and illiteracy

especially of the cattle Fulani is recognised but there is already evidence to show that this can be solved.

Nigeria has the capability of increasing livestock production to levels that will meet the needs of its human population within the next few years. The most crucial ingredient in the transformation process is an effective extension network.

#### REFERENCES

- ADEOYE, A.O., 1979. Problems of poultry extension work in Kwara State. Paper presented at the in-service training programme for Kwara State poultry extension workers. May 1979.
- AJAKAIYE, M.B., 1979. Extension Services in the livestock sector of Agriculture. Paper presented at the International Symposium on the Intensification of Livestock Production in the Sub-humid tropics of West Africa.
- BALOGUN, S.T., 1976. Local Extension around Samaru Proceedings of the annual livestock and veterinary conference. Ahmadu Bello University, Zaria.
- FEDERAL LIVESTOCK DEPARTMENT, 1975. Touring reports of the J.P. 28 publicity team. Veterinary public and Animal Health Division, Kaduna.
- NURU, S., 1979. Possible strategies and management approach to increase livestock production in Nigeria. Paper presented.

OLAIFA, O.O., 1979. The impact of O.F.N. on poultry production in Nigeria. Paper presented at the continuing Education course for practising veterinarians and senior livestock officers. Ahmadu Bello University, Zaria.

F.A.O., 1966. Agricultural Development in Nigeria, 1965—80 Rome.

OLUMEYAN, D.B., 1978. The impact of middle level manpower training of National Livestock Development. Paper presented at the 8th annual livestock and veterinary conference. Ahmadu Bello University, Zaria.

YAZIDU, I., and W.L. PRAWL. 1975. The study of Radio as a means of communicating Agricultural Information to farmers in the Northern States of Nigeria. Co-operative Extension Service, Kansas State University — Extension studies No. 11.

YAZIDU, I., 1978. Role of Extension Services in Nigeria Paper presented at the Annual Livestock and Veterinary conference. Ahmadu Bello University, Zaria.

<i>Section</i>	<i>Subject</i>
A	— Nutrition/Pasture and Forage Utilisation.
B	— Reproduction
C	— Economics
D	— Livestock Diseases
E	— General